

DATA SHEET

TMI-Orion Dynamics

Electrical Manipulator Arm



Reliable and rugged manipulator for underwater operations.

The Electrical Manipulator Arm (EMA) is a high performance, compact and reliable multi-function manipulator designed for underwater operation.

SPECIAL FEATURES

- Depth rate: 500 m (air filled)
- 3, 4 or 5 functions: slew, elevation, elbow, rotate, jaw (close/open) - Multiple jaws available,
- 3 connectors available for add-on capacities (cameras, projectors, lasers...),
- Easy to operate - Easy to switch,
- Compact design with embedded electronic controller (No additional POD required),
- Built-in control command with game pad or cartesian mode,
- Maintenance free,
- Easy mounting for left or right arm.

TECHNICAL SPECIFICATIONS

Functions	Slew	Elevation	Elbow bend	Jaw	Jaw rotation
	127°	120°	120°	close/open	continuous

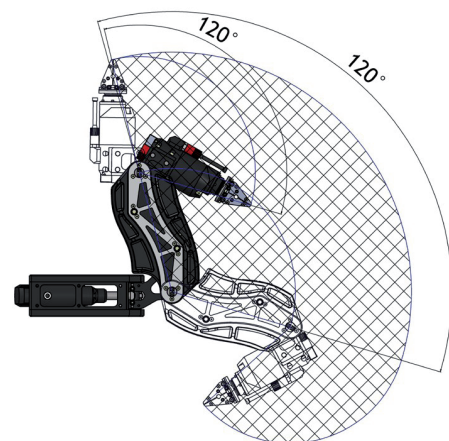
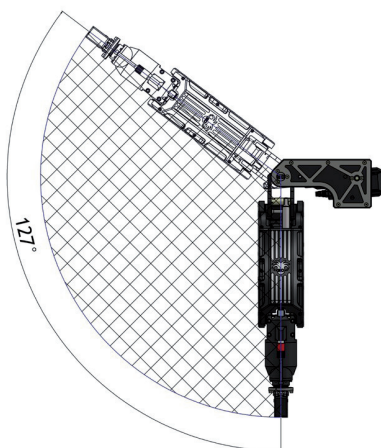



TECHNICAL SPECIFICATIONS

Depth rating	500 m (Air filled)
Lift capabilities (full extension)	16 kg dynamic 50 kg static strength
Full reach length (fully extended from slew pivot)	700 mm
Material	Polyethylene, hard anodized aluminum 5083 and Stainless Steel
Weight	17 kg in air 9 kg in fresh water
Height in stowed position	459 mm
Operating temperature	-10°C to +60°C
Storage temperature	-20°C to +60°C
Power supply	9-24 VDC. The characteristics are done with 24 VDC nominal (150 W max.)
Serial control bus	RS485 (115 200 bauds)
Connector	In: SubConn / out: SubConn MCBH8F
Built-in control command	Game pad or cartesian mode

SOFTWARE AND RELATED PRODUCTS

Monitoring software

The Electrical Manipulator Arm comes with a monitoring software dedicated to remote operation from TMI-Orion Surface Control Unit (To be ordered separately).

Other products

The Electrical Manipulator Arm can also be equipped with other TMI-Orion standard modules such as cameras, sensors...



Electrical Manipulator Arm



TMI-Orion Dynamics Surface Control Unit

TMI-Orion S.A.
Parc Bellegarde - Bâtiment A
1, chemin de Borie
34170 Castelnau-le-Lez - France
T.: +33 (0)4 99 52 67 10 – F.: +33 (0)4 99 52 67 19



www.tmi-orion-dynamics.com

USA : TMI-USA, Inc.
11491 Sunset Hills Road, Suite 310
Reston, VA 20190 - USA
T : +1 703 668 0114 – F : +1 703 668 0118